

Induction Motor

60 Watt

Frame Size: □ 90 mm

Continuous Rating, TEFC Aluminium Die Cast Body.
Rotates in clock wise or counter clock wise direction.
Over runs after few rotations after supply is cutt off.
Speeds are 2880 / 1440 and further low speeds with the gearbox.
Terminal box or open lead wires for connections.

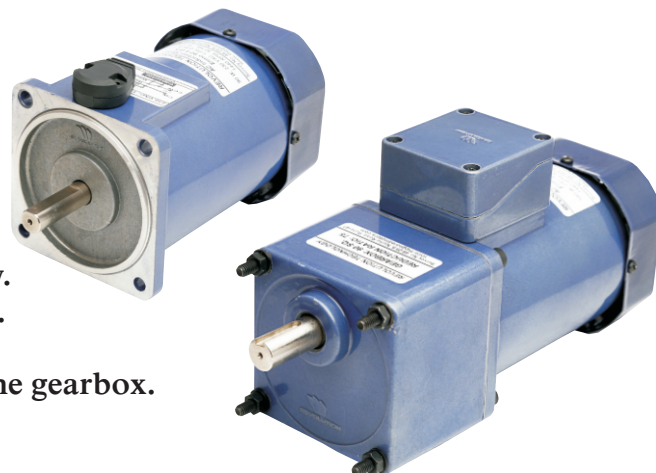

Specifications :

Output Power W	Model	Frequency Hz	Supply Voltage Volt	Current A	Starting Torque Kg.cm	Rated Torque Kg.cm	Rated Speed RPM	Capacitor μF
60	90 4G IW 60	60	110 V Single Phase	1.15	3.2	3.7	1500	10
60	90 4G IX 60	50	230 V Single Phase	0.56	3.7	4.4	1250	2.5
60	90 4G IY 60	60	230 V Three Phase	0.46	3.8	3.8	1500	-----
60	90 4G IY 60	50	230 V Three Phase	0.54	4.3	4.4	1330	-----
60	90 4G IZ 60	50	415 V Three Phase	0.31	4.3	4.4	1330	-----

Gearmotor Torque Table:

The maximum permissible torque is 200 kg.cm

50 Hz

Unit: kg.cm

RPM	500	416	300	250	200	166	120	100	83	60	50	41	30	25	20	16	15	12.5	10	8.3
Gear Ratio	3	3.6	5	6	7.5	9	12.5	15	18	25	30	36	50	60	75	90	100	120	150	180
Output Torque	12	15	20	25	30	36	45	56	64	80	98	115	144	173	200	200	200	200	200	200

60 Hz

Unit: kg.cm

RPM	600	500	360	300	240	200	144	120	100	72	60	50	36	30	24	20	18	15	12	10
Gear Ratio	3	3.6	5	6	7.5	9	12.5	15	18	25	30	36	50	60	75	90	100	120	150	180
Output Torque	9.8	12	16	20	25	30	37	45	53	68	80	98	134	159	180	200	200	200	200	200

Gear Boxes are sold separately.

A Sky blue colored background indicates gear shaft rotation in the same direction; a Brown background indicates rotation in the opposite direction as the motor shaft.

The speed of the Gear Motor is calculated by dividing the motor's synchronous speed (50 Hz; 1500 RPM & 60 Hz; 1800 RPM) by the ratio.

The actual speed is 2~20% less than the displayed value, depending upon the load size.

Characteristics, specifications and dimensions are subjected to change without prior notice.

60 Watt : AC Geared Motor With Terminal Box

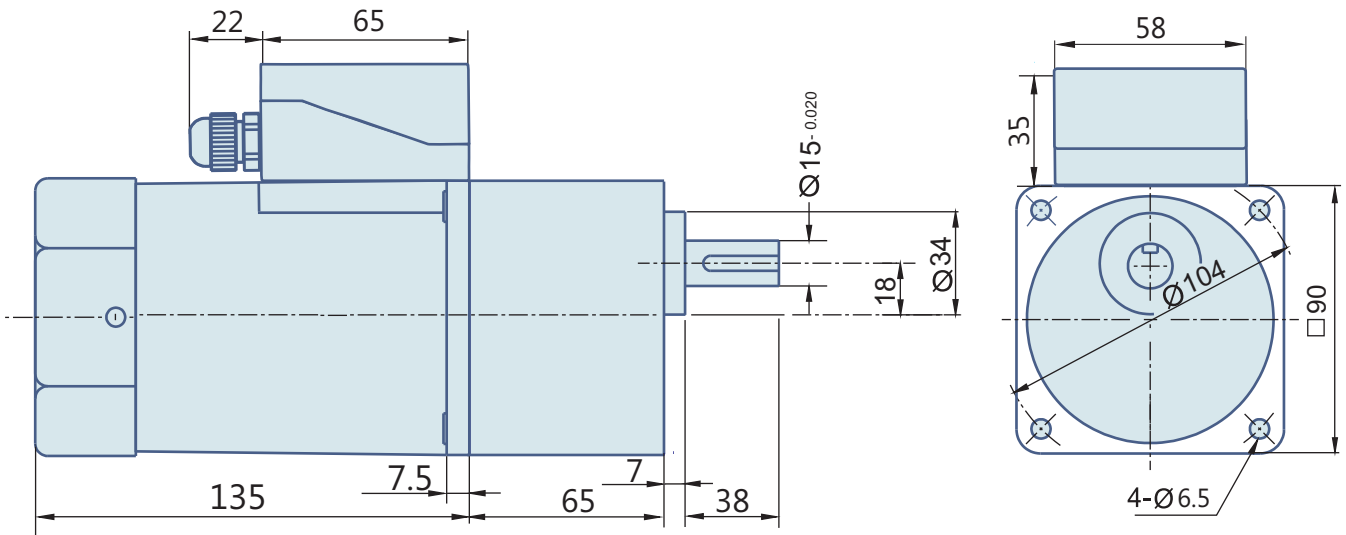

60 Watt : Round AC Induction Motor With Terminal Box

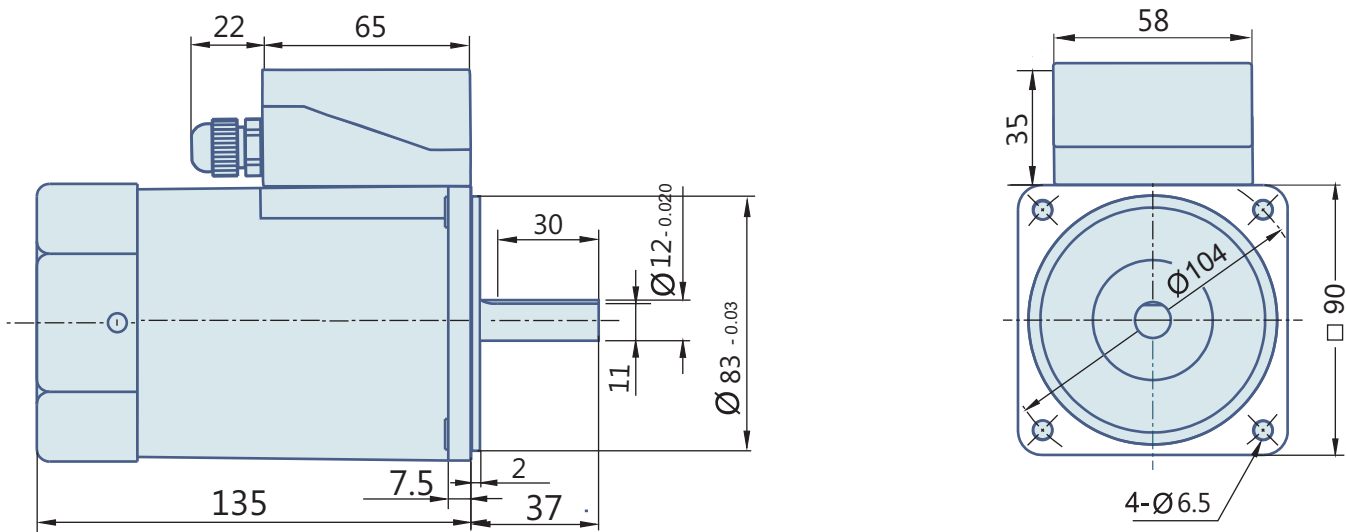

60 Watt : AC Geared Motor With Lead wires

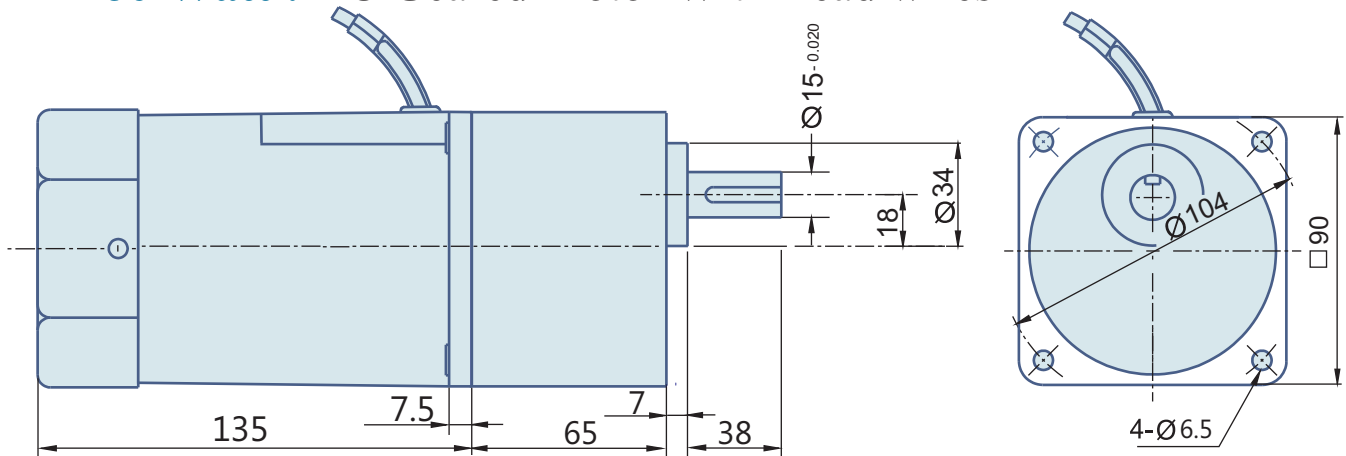

Key and Keyway

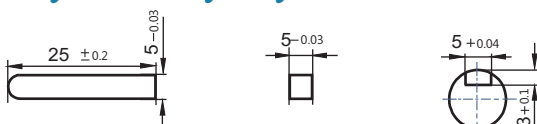

Weight

Motor: 2.6 Kg, Gearbox: 1.5 Kg

(Note- All Dimensions are in mm)

Wiring Diagram

Wiring diagram for Single Phase Motors

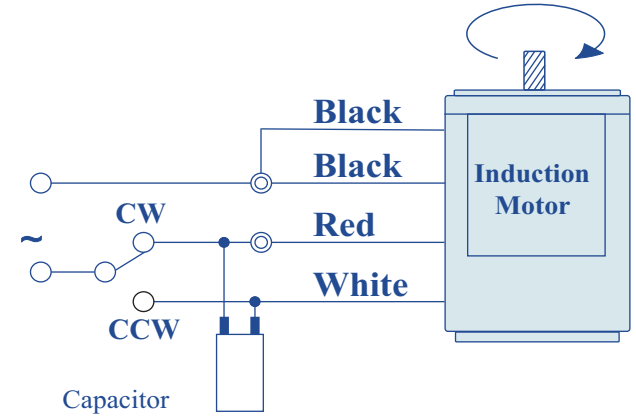
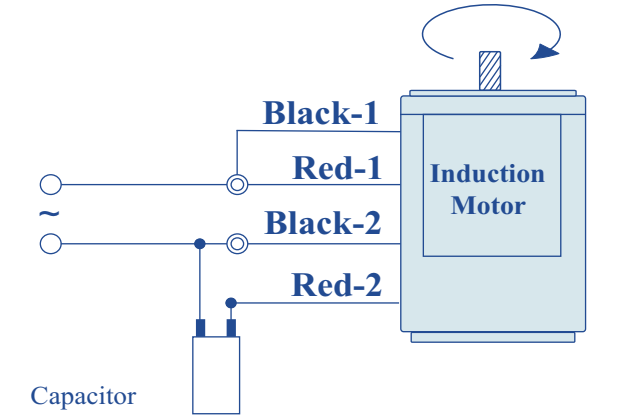
Standard Single Phase Motor	SR Type Single Phase Motor
	
<p>Short the Black wires and connect as shown in fig., To rotate the motor in Clockwise direction.</p> <p>To change the direction, flip CW to CCW.</p>	<p>Black Wires are for Starting purpose and Red wires for the Running purpose, as shown in fig.,</p> <p>To change the direction, interchange Black wires or Red wires.</p>

Wiring diagram for Three Phase Motors

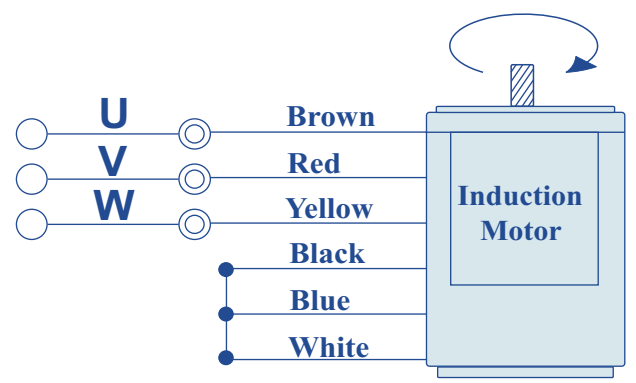
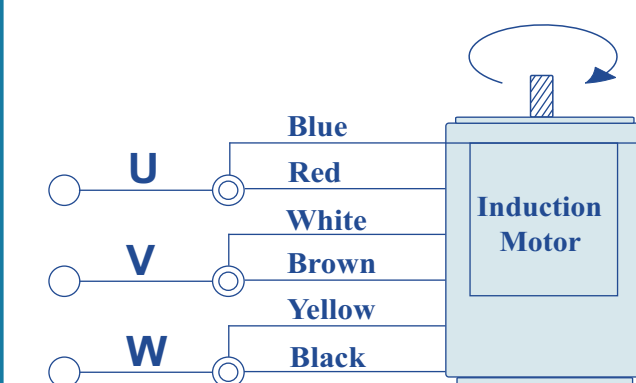
Star Connection	Delta Connection
	
<p>For the Voltage 415 VAC, 3-Phase Supply, Wires are connected as shown in the fig. Short Blue, Black and White and then insulate it carefully.</p> <p>To change the direction, interchange any two wires between U, V & W.</p>	<p>For the Voltage 230 VAC, 3-Phase Supply, Wires are connected as shown in the fig. Short Blue & Red, Black & Yellow, and White & Red as per the fig. Shown.</p> <p>To change the direction, interchange any two wires between U, V & W.</p>

Change the direction of the motor only after it stops rotating, if the attempt is made during rotation, the motor may ignore the reversing command or change the direction after some time.